



# CCX896

## 8 inch Subcardioid Coaxial Loudspeaker

*tq* install™  
SERIES



### Overview

The CCX896 is a coaxial, passive subcardioid loudspeaker that provides 7 dB of low frequency attenuation in the rear hemisphere while still providing the output capability of a normal 2-way system in a much more compact enclosure. Its coaxial transducer and 90° x 60° horn can be rotated in 45° increments, which allows its coverage to be tailored to best suit an application's requirements. The enclosure's vertically trapezoidal shape allows it to be installed very close to ceilings or beneath large arrays with minimal effect on sight lines.

Fulcrum Acoustic's **TQ™** processing is an integral part of the CCX896 design. Sound, innovative acoustical design combined with state of the art digital processing leads to exceptional clarity and precise transient response, even at very high sound pressure levels. The required digital signal processing can be provided by one of many supported platforms.

The CCX896 is particularly effective for fill systems where targeted pattern control is desirable. In addition, its 16 ohm nominal impedance makes it an excellent solution for high fidelity, foreground distributed systems where a high loudspeaker-to-amplifier ratio is desirable. Its unique shape and compact size complements many architectural styles, which facilitates acceptance by interior designers and architects. This makes it the perfect choice for houses of worship, theaters, restaurants, transportation facilities, theme parks, and more.

### Performance Specifications<sup>1</sup>

#### Operating Mode

Single-amplified w/ DSP

#### Operating Range<sup>2</sup>

81 Hz to 20 kHz

#### Nominal Beamwidth (rotatable)

90° x 60°

#### Transducers

HF/LF: Coaxial 1.7 inch titanium diaphragm compression driver; 8.0 inch woofer, 2.0 inch voice coil; single neodymium magnet

#### Power Handling @ Nominal Impedance<sup>3</sup>

63 V / 250 W @ 16 Ω

#### Nominal Sensitivity @ Input Voltage<sup>4</sup> (whole space)

104 dB @ 4.00 V

#### Nominal Maximum SPL (peak / continuous)

134 dB / 128 dB

#### Equalized Sensitivity @ Input Voltage<sup>5</sup>

95 dB @ 4.00 V

#### Equalized Maximum SPL<sup>6</sup> (peak / continuous)

125 dB / 119 dB

#### Recommended Power Amplifier

250 W to 500 W @ 16 Ω

### Physical Specifications

#### Connections

(2) Neutrik NL4 Speakon

Pin 1+/-: Full Range

Pin 2+/-: NC

#### Mounting / Suspension Points

(2) M6 x 1.0 yoke points, (2) M6 x 1.0 pull back points

#### Dimensions / Weight

See page 6

#### Finish

Black painted enclosure w/ matte black grille, or

White painted enclosure w/ matte white grille

### Options

YK-CX8 yoke bracket, Terminal strip input, Custom color finish, Weather-resistant (WR) enclosure & hardware



Axial Sensitivity (dB SPL, 4.00 V @ 1 m)<sup>7,8</sup>

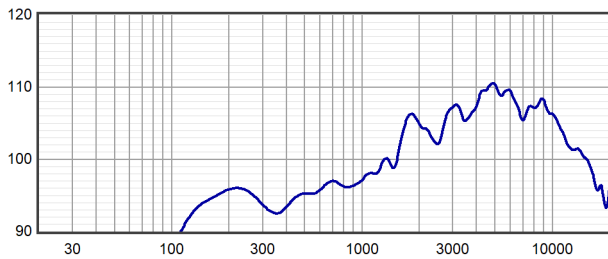

Horizontal Off Axis Response<sup>7,11</sup>

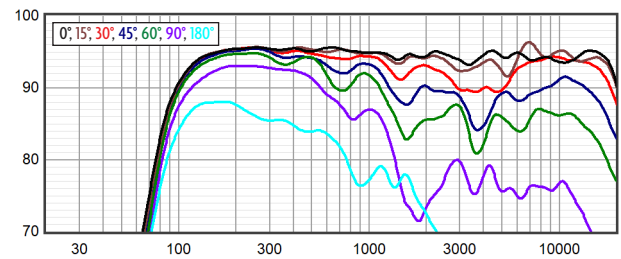

Axial Processed Response (dB)<sup>7,9</sup>

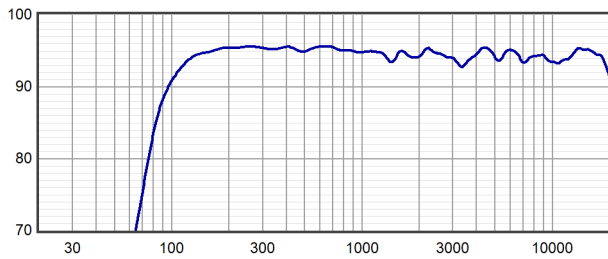

Vertical Off Axis Response<sup>7,11</sup>

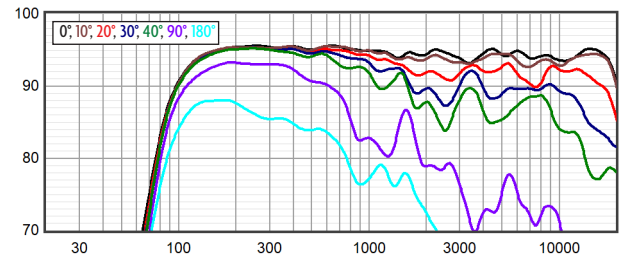

Axial Processed Phase Response (degrees)<sup>7,10</sup>

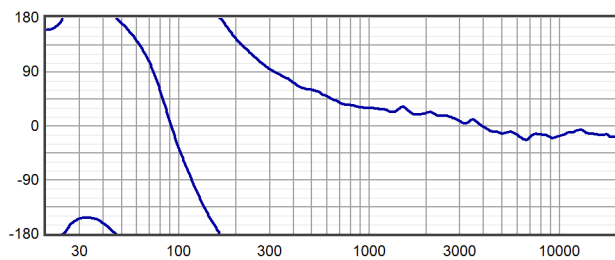

Beamwidth<sup>7,12</sup>

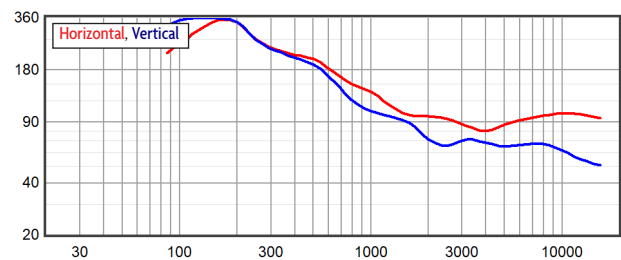

Impedance (ohms)

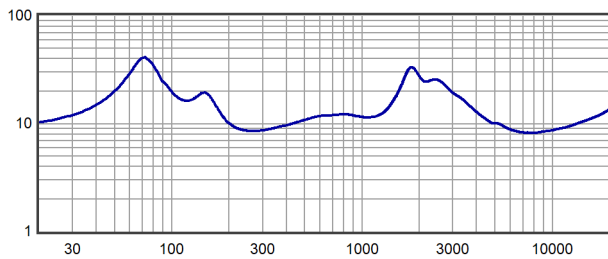

Directivity Index (dB)<sup>13</sup>

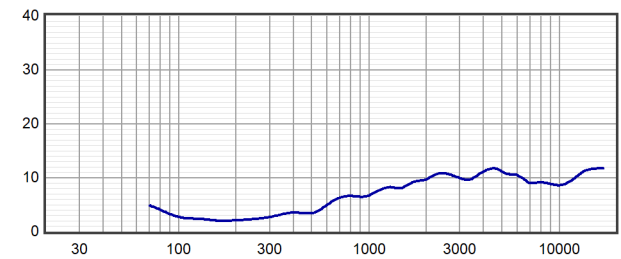



Horizontal Polar Response (30 dB Scale, 6 dB per Major Division)

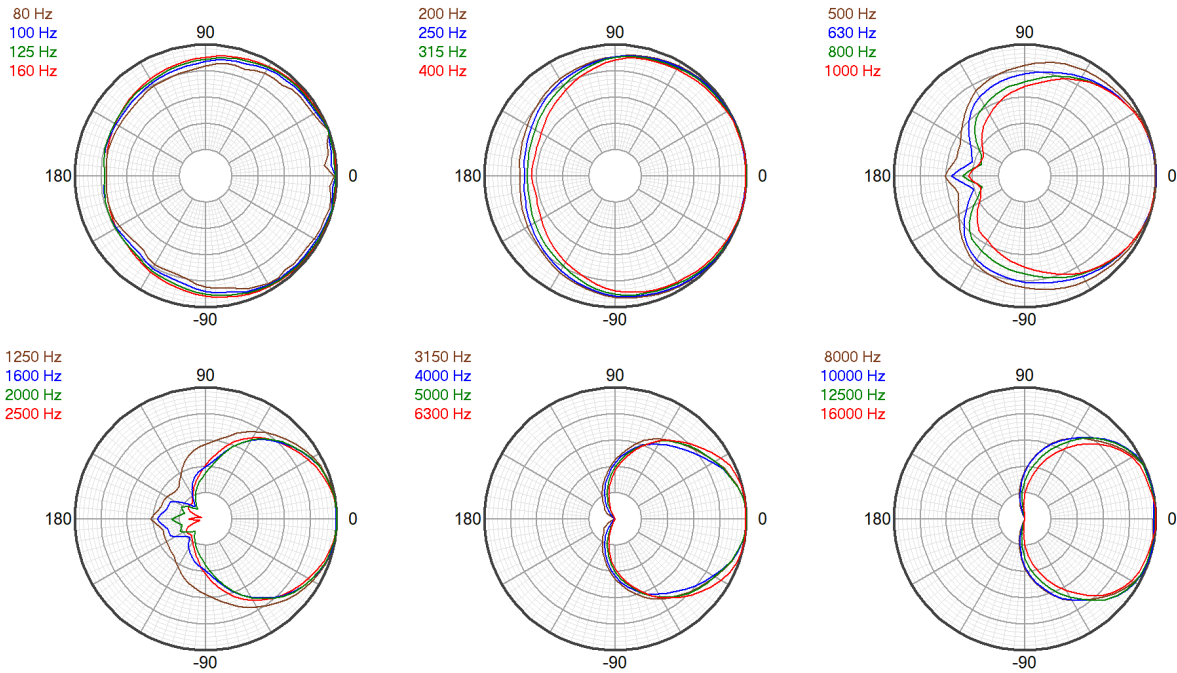

Vertical Polar Response (30 dB Scale, 6 dB per Major Division)

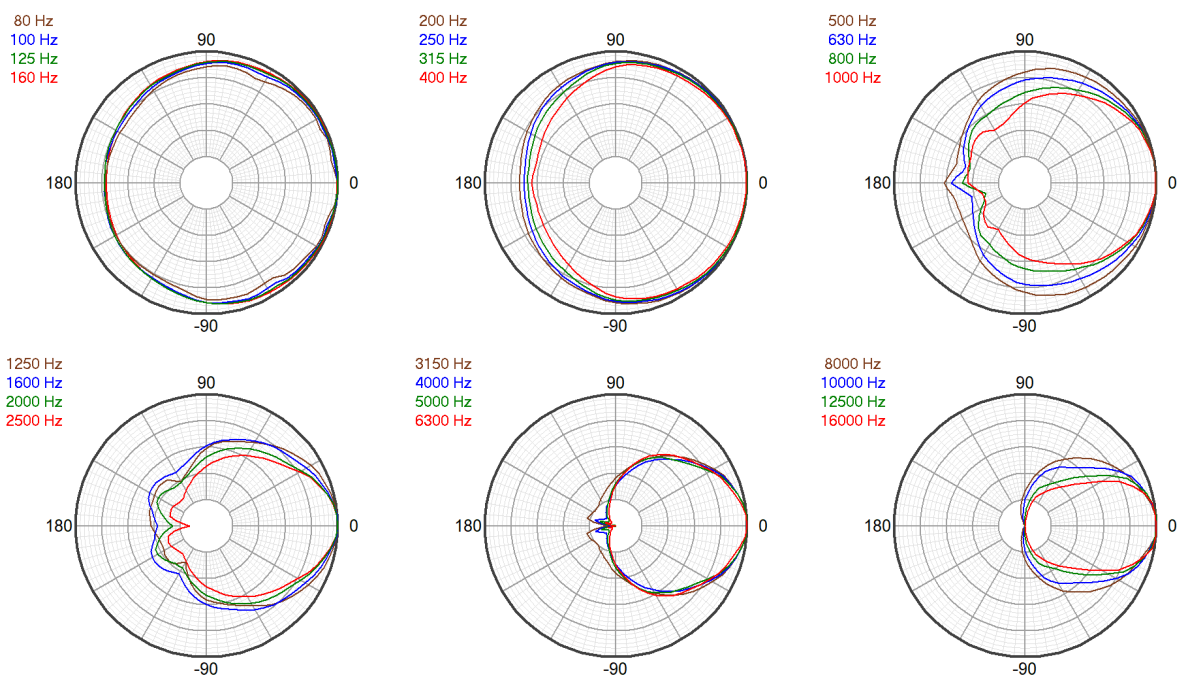



### Technologies

The CCX896 incorporates Fulcrum's patented\* Passive Cardioid Technology™ to overcome one of the major challenges of other loudspeakers: rear LF radiation. Unlike active cardioid loudspeakers, Fulcrum's passive cardioid technology does not require an additional amplifier channel or additional transducer to achieve its 7 dB of rear rejection.

The subcardioid behavior is produced by a meticulously conceived acoustical circuit which balances the position of the low frequency driver, the enclosure depth and volume, and specially constructed rear-mounted ports which include a calibrated resistive element. By opting for a subcardioid pattern as opposed to a pure, hyper or super cardioid pattern, the attenuation is more consistent over the rear hemisphere, and low frequency efficiency is preserved.

The CCX896 includes a neodymium-based coaxial transducer which allows the compression driver diaphragm to be positioned very close to the woofer voice coil. This allows the system to maintain coherent summation and consistent off axis response through a passive crossover, allowing it to be powered with a single amplifier channel.

The compression driver's 1.75 inch diameter diaphragm operates to a relatively low frequency. This allows the high frequency horn to smooth the polar response of the low frequency section in the frequency range where the horn would otherwise cause shadowing. The coaxial woofer's large radiating surface works in conjunction with the HF horn to improve directional control at the low frequency limit of the horn's operating range, increasing directional control beyond what can be accomplished by the horn alone.

### Connection Diagram

2-way, Single-Amp

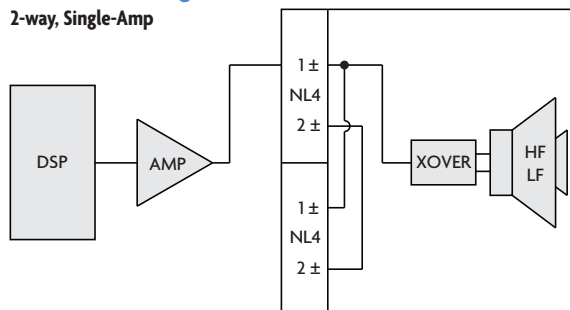

### Mechanical Specification Drawings

2D and 3D DWG dimensional drawings are available for download at [www.fulcrum-acoustic.com/support](http://www.fulcrum-acoustic.com/support).

\* Gunness, D. (2018). *Passive Cardioid Speaker* (U.S. Patent No. 10,123,111 B2). U.S. Patent and Trademark Office. [tinyurl.com/yehr3wv4](http://tinyurl.com/yehr3wv4)



## Notes

- <sup>1</sup> **Performance Specifications** All acoustic specifications rounded to nearest whole number. External DSP with Fulcrum Acoustic-provided settings is required to achieve the specified performance.
- <sup>2</sup> **Operating Range** The frequency range within which the processed response is within 10 dB of the average.
- <sup>3</sup> **Power Handling** Based on the AES power handling of the transducers.
- <sup>4</sup> **Nominal Sensitivity** The 1-meter-referenced SPL produced by a 1 watt band limited pink noise signal, with no processing applied.
- <sup>5</sup> **Equalized Sensitivity** The 1-meter-referenced SPL produced when an EIA-426-B signal is applied to an equalized loudspeaker system, at a level which produces a total power of 1 watt, in sum, to the loudspeaker subsections.
- <sup>6</sup> **Equalized Maximum SPL** The 1-meter-referenced SPL produced when an EIA-426-B signal is applied to an equalized loudspeaker system, at a level which drives at least one subsection to its rated power.
- <sup>7</sup> **Resolution** All response graphs are subjected to 1/6 octave cepstral smoothing with a gaussian weighting function.
- <sup>8</sup> **Axial Sensitivity** The SPL plotted against frequency for a 1 watt swept sine wave, referenced to 1 m with no signal processing.
- <sup>9</sup> **Axial Processed Response** The axial magnitude response with recommended signal processing applied.
- <sup>10</sup> **Axial Processed Phase Response** The axial phase response with recommended signal processing applied, and latency removed.
- <sup>11</sup> **Horizontal / Vertical Off Axis Responses** The magnitude response at various angles off axis, with recommended signal processing applied.
- <sup>12</sup> **Beamwidth** The angle between the -6 dB points in a loudspeaker's polar response.
- <sup>13</sup> **Directivity Index (Di)** The ratio of the on-axis sound pressure squared to the spherical average of the sound pressure squared at a particular frequency expressed in dB. To convert the directivity index to directivity factor (Q) use the formula  $10^{Di/10}$ .



product specification

Notes:

1. Net Weight = Approx. 17.0 lb / 7.7 kg
2. Ship Weight = Approx. 22.0 lb / 10.0 kg
3. Symbol  = M6 nut plate
4. Symbol  = CoG
5. Drawing representative of:  
CCX896, CCX826

REVISIONS		
REV	DESCRIPTION	APPR / DATE
1	NEW ISSUE	RAF 6/2/22

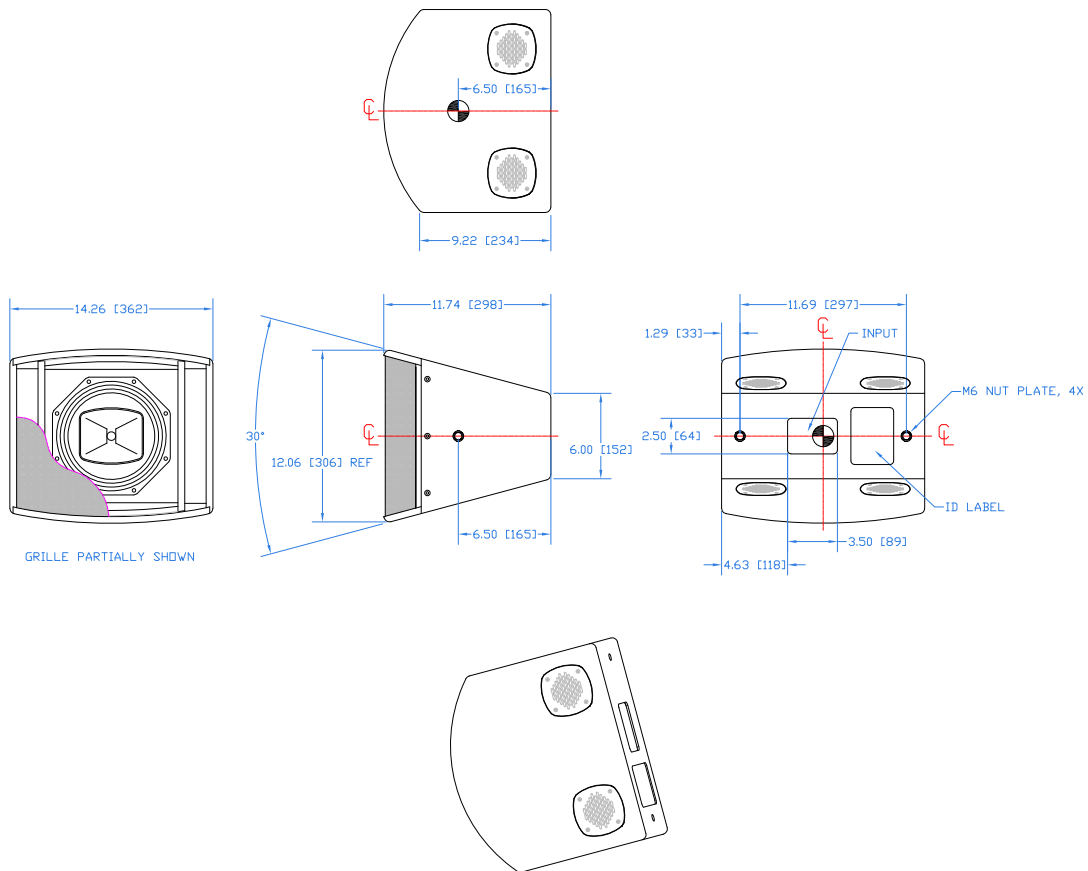

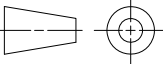
<p>THIRD ANGLE PROJECTION</p> 	<p>UNLESS OTHERWISE SPECIFIED: ALL DIMENSIONS ARE IN INCHES</p> <p>TOLERANCE IN INCHES .XX±.015 .XXX±.005 FRACTIONS ±1/32 ANGLES ±1/2°</p> <p>(X.XX) = REF DIMS NO TOLERANCE IMPLIED</p> <p>TSC = THEORETICAL SHARP CORNER</p> <p>DIMENSIONS ACROSS CENTERLINES TO BE SYMMETRICAL</p>	<p>STATUS RELEASED</p>		<p>FULCRUM ACOUSTIC, LLC 670 LINWOOD AVE., LINWOOD, MA 01525 USA</p>
		<p>APPROVALS</p> <p>DRAWN: RAF</p> <p>CHECKED: DEW</p> <p>DES ENG:</p> <p>MFG ENG:</p>	<p>DATE</p> <p>6/2/22</p> <p>6/2/22</p>	
<p>THIS DRAWING IS THE PROPERTY OF FULCRUM ACOUSTIC, AND SHALL NOT BE COPIED, REPRODUCED, OR USED AS THE BASIS FOR MANUFACTURE OR SALE OF APPARATUS WITHOUT WRITTEN AUTHORIZATION. DO NOT SCALE DRAWING.</p>		<p>A</p>	<p>SHEET 1 OF 1</p>	<p>SCALE: 1:12</p>
		<p>DWG. NO. 820-100-155</p>	<p>REV 1</p>	

Drawing is reduced. Do not scale.



product specification, weather-resistant (WR) version

Notes:

1. Net Weight = Approx. 17.5 lb / 7.9 kg
2. Ship Weight = Approx. 22.5 lb / 10.2 kg
3. Symbol = M6 nut plate
4. Symbol = CoG
5. Enclosure construction: PVC
6. Drawing representative of:  
CCX896-WR, CCX826-WR

REVISIONS		
REV	DESCRIPTION	APPR / DATE
1	NEW ISSUE	RAF 6/2/22

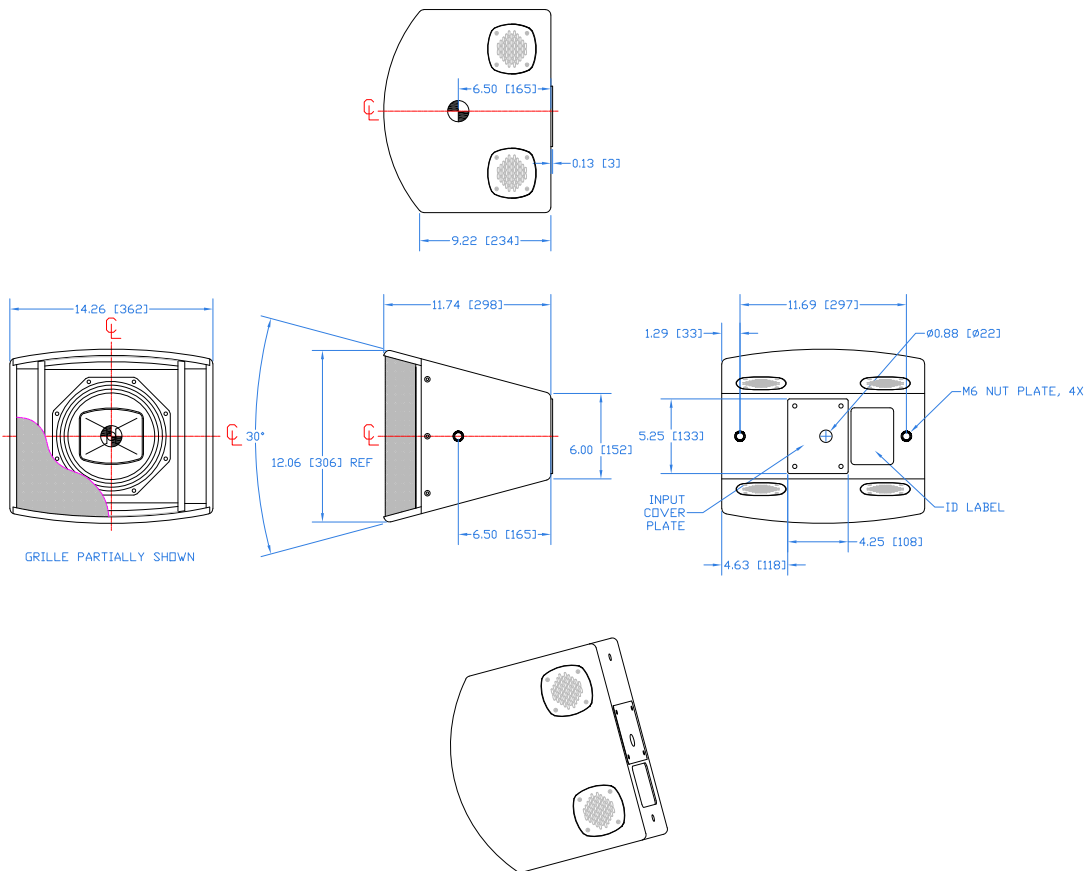

<p>THIRD ANGLE PROJECTION</p>	<p>UNLESS OTHERWISE SPECIFIED: ALL DIMENSIONS ARE IN INCHES</p> <p>TOLERANCE IN INCHES .XX±.015 .XXX±.005 FRACTIONS ±1/32 ANGLES ±1/2°</p> <p>(XXX) = REF DIMS NO TOLERANCE IMPLIED</p> <p>TSC = THEORETICAL SHARP CORNER</p> <p>DIMENSIONS ACROSS CENTERLINES TO BE SYMMETRICAL</p>	<p>STATUS RELEASED</p>		<p>FULCRUM ACOUSTIC, LLC 670 LINWOOD AVE., LINWOOD, MA 01525 USA</p>	
		<p>APPROVALS</p> <p>DATE</p>	<p>DATE</p>		<p>TITLE:</p> <p>Mechanical Spec, CCX8 Series - WR</p>
<p>THIS DRAWING IS THE PROPERTY OF FULCRUM ACOUSTIC, AND SHALL NOT BE COPIED, REPRODUCED, OR USED AS THE BASIS FOR MANUFACTURE OR SALE OF APPARATUS WITHOUT WRITTEN AUTHORIZATION. DO NOT SCALE DRAWING.</p>	<p>DWG. NO. 820-100-156</p>	<p>DRAWN: RAF</p>	<p>6/2/22</p>	<p>SHEET 1 OF 1</p>	<p>SCALE: 1:12</p>
		<p>CHECKED: DEW</p>	<p>6/2/22</p>	<p>REV 1</p>	
		<p>DES ENG:</p>			
<p>MFG ENG:</p>					

Drawing is reduced. Do not scale.

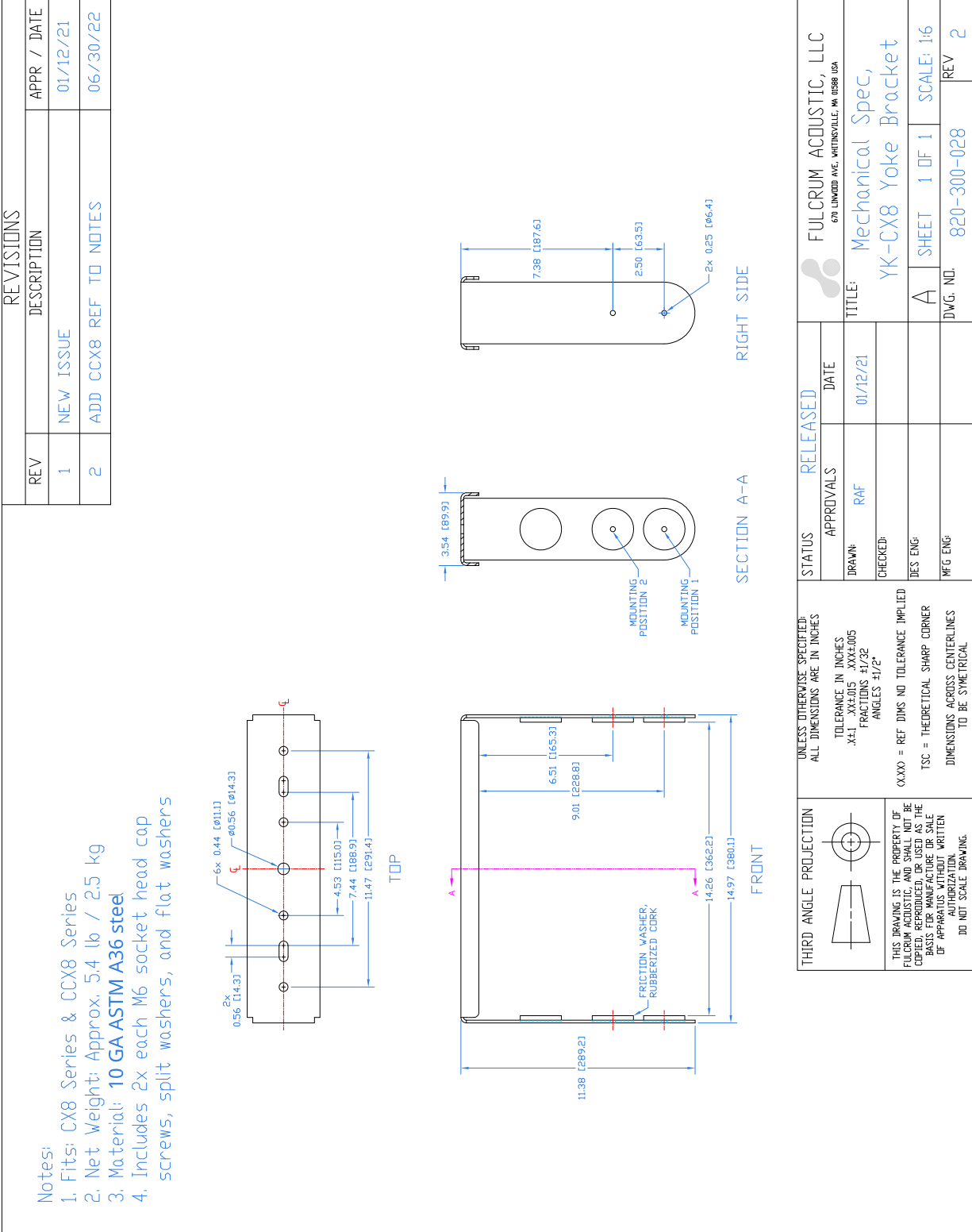

Drawing is reduced. Do not scale.

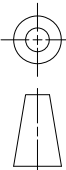
THIRD ANGLE PROJECTION		THIS DRAWING IS THE PROPERTY OF FULCRUM ACOUSTIC, AND SHALL NOT BE COPIED, REPRODUCED, OR USED AS THE BASIS FOR MANUFACTURE OF ANY APPARATUS WITHOUT WRITTEN AUTHORIZATION. DO NOT SCALE DRAWING.	UNLESS OTHERWISE SPECIFIED: ALL DIMENSIONS ARE IN INCHES TOLERANCE IN INCHES .X41 .XX4.015 .XXX4.005 FRACTIONS 41/32 ANGLES 41/2° (X.XX) = REF DIMS NO TOLERANCE IMPLIED TSC = THEORETICAL SHARP CORNER DIMENSIONS ACROSS CENTERLINES TO BE SYMMETRICAL.	STATUS: RELEASED APPROVALS: RAF DRAWN: CHECKED: TIES ENG: MFG ENG:	DATE: 01/12/21
TITLE: Mechanical Spec, YK-CX8 Yoke Bracket		FULCRUM ACOUSTIC, LLC 670 LINDOOD AVE. WHTINSVILLE, IN 46088 USA			
A SHEET 1 OF 1 SCALE: 1:6		DWG. NO. 820-300-028 REV 2			



	REV	DESCRIPTION	APPR / DATE
	1	NEW ISSUE	RAF 01/12/21
	2	ADD CCX8 REF TO NOTES	RAF 06/30/22

**Notes:**  
 The YK-CX8 yoke bracket is designed to mount CX8 & CCX8 Series loudspeakers in a horizontal orientation. It is fitted with two mounting holes which allow the installer to vary the distance between the loudspeaker enclosure and the mounting surface.

Note that the range of motion is restricted when the enclosure is mounted closer to the yoke. The maximum range of motion is achieved when the enclosure is mounted to the holes nearest the end of the bracket arms.

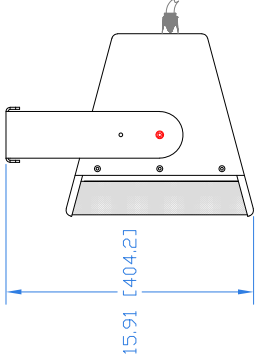

15.91 [404.2]

MOUNTING POSITION 1

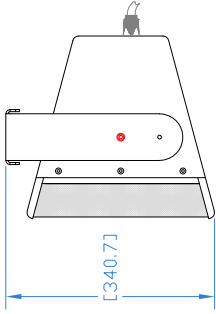

13.41 [340.7]

MOUNTING POSITION 2

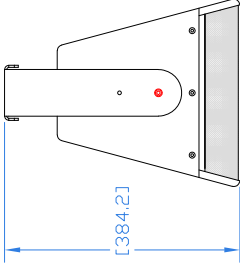

15.13 [384.2]

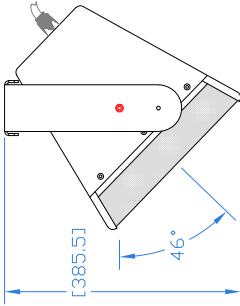

15.18 [385.5]

46°

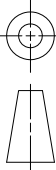
	THIRD ANGLE PROJECTION	UNLESS OTHERWISE SPECIFIED: ALL DIMENSIONS ARE IN INCHES TOLERANCE IN INCHES .X41 .XXE.015 .XXXE.005 FRACTIONS 1/16 1/32 ANGLES 1/2°	STATUS	RELEASED	
			APPROVALS	DATE	FULCRUM ACOUSTIC, LLC 670 LINDOOD AVE. WHTINSVILLE, IN 46088 USA
	THIS DRAWING IS THE PROPERTY OF FULCRUM ACOUSTIC, AND SHALL NOT BE COPIED, REPRODUCED, OR USED AS THE BASIS FOR MANUFACTURE OR REPAIR OF APPARATUS WITHOUT WRITTEN AUTHORIZATION. DO NOT SCALE DRAWING.	(X.XX) = REF DIMS NO TOLERANCE IMPLIED TSC = THEORETICAL SHARP CORNER DIMENSIONS ACROSS CENTERLINES TO BE SYMMETRICAL	DRAWN	01/12/21	TITLE: Mechanical Spec, YK-CX8 + CX8xx Assembly
			CHECKED:		A SHEET 1 OF 1 SCALE: 1:8
			DES'G:		DWG. NO. 820-300-029 REV 2
			MFG ENG:		

Drawing is reduced. Do not scale.