

SAM412T

ANALOGUE PREAMPLIFIERS & MIXERS

Installation Analogue Mixer



USER MANUAL

INDEX

| | |
|---|----|
| 1. IMPORTANT REMARK..... | 3 |
| 2. IMPORTANT SAFETY INSTRUCTIONS..... | 4 |
| 3. IMPORTANT NOTE..... | 5 |
| 4. INTRODUCTION..... | 5 |
| 4.1. Main Features..... | 5 |
| 5. INSTALLATION..... | 6 |
| 6. INPUTS..... | 6 |
| 7. OUTPUTS..... | 8 |
| 8. STARTING UP..... | 9 |
| 9. EQUALIZATION..... | 9 |
| 10. VU-METER..... | 9 |
| 11. GROUND LOOPS, BACKGROUND NOISE..... | 9 |
| 12. CLEANING..... | 10 |
| 13. DIAGRAMS..... | 11 |
| 13.1. Control Panels Function..... | 11 |
| 13.2. Side Position..... | 12 |
| 13.3. Configuration Diagram..... | 12 |
| 13.4. Block Diagram..... | 13 |
| 14. TECHNICAL SPECIFICATIONS..... | 14 |

1. IMPORTANT REMARK



WARNING: SHOCK HAZARD - DO NOT OPEN
AVIS: RISQUE DE CHOC ÉLECTRIQUE - NE PAS OUVRIR



The lightning flash with arrowhead symbol, within an equilateral triangle, is intended to alert the user to the presence of uninsulated “dangerous voltage” within the product’s enclosure that may be of sufficient magnitude to constitute a risk of electric shock to persons.



The exclamation point within an equilateral triangle is intended to alert the user to the presence of important operating and maintenance (servicing) instructions in the literature accompanying the appliance.

WARNING (If applicable): The terminals marked with symbol of “” may be of sufficient magnitude to constitute a risk of electric shock. The external wiring connected to the terminals requires installation by an instructed person or the use of ready-made leads or cords.

WARNING: To prevent fire or shock hazard, do not expose this equipment to rain or moisture.

WARNING: An apparatus with Class I construction shall be connected to a mains socket-outlet with a protective earthing connection.

2. IMPORTANT SAFETY INSTRUCTIONS

1. Read these instructions.
2. Keep these instructions.
3. Heed all warnings.
4. Follow all instructions.
5. Do not use this apparatus near water.
6. Clean only with dry cloth.
7. Do not block any ventilation openings. Install in accordance with the manufacturer's instructions.
8. Do not install near any heat sources such as radiators, heat registers, stoves, or other apparatus (including amplifiers) that produce heat.
9. Do not defeat the safety purpose of the polarized or grounding type plug. A polarized plug has two blades with one wider than the other. A grounding type plug has two blades and a third grounding prong. The wide blade or the third prong are provided for your safety. If the provided plug does not fit into your outlet, consult an electrician for replacement of the obsolete outlet.
10. Protect the power cord from being walked on or pinched particularly at the plugs, convenience receptacles, and at the point where they exit from the apparatus.
11. Only use attachments/accessories specified by the manufacturer.
12. Unplug the apparatus during lightening sorts or when unused for long periods of time.
13. Refer all servicing to qualified personnel. Servicing is required when the apparatus has been damaged in any way, such as power supply cord or plug is damaged, liquid has been spilled or objects have fallen into the apparatus, the apparatus has been exposed to rain or moisture, does not operate normally, or has been dropped.
14. Disconnecting from mains: When switching off the POWER switch, all the functions and light indicators of the unit will be stopped, but fully disconnecting the device from mains is done by unplugging the power cable from the mains input socket. For this reason, it always shall remain easily accessible.
15. Equipment is connected to a socket-outlet with earthing connection by means of a power cord.
16. The marking information is located at the bottom of the unit.
17. The apparatus shall not be exposed to dripping or splashing and that no objects filled with liquids, such as vases, shall be placed on apparatus.



WARNING: This product must not be discarded, under any circumstance, as unsorted urban waste. Take to the nearest electrical and electronic waste treatment centre.

NEEC AUDIO BARCELONA, S.L. accepts no liability for any damage that may be caused to people, animal or objects due to failure to comply with the warnings above.

3. IMPORTANT NOTE

Thank you for choosing our Ecler **SAM412T Installation Analogue Mixer!**

It is **VERY IMPORTANT** to carefully read this manual and to fully understand its contents before any connection in order to maximize your use and get the best performance from this equipment.

To ensure optimal operation of this device, we strongly recommend that its maintenance be carried out by our authorised Technical Services.

All ECLER products are covered by warranty, please refer to www.ecler.com or the warranty card included with this product for the period of validity and conditions.

4. INTRODUCTION

The SAM412T is an easy-to-use professional mixer designed for PA applications.

4.1. Main Features

- 4 MIC/LINE input channels.
- Adjustable microphone sensitivity on the back panel.
- +18 V DC *Phantom* power supply available for all "MIC" inputs.
- Direct microphone input on the front panel, channel 1.
- Included *Talkover* assigned to input 1, with internal recovery time selector.
- 3-Band tone controls, adjustable with a screwdriver.
- Mix output VU-meter.
- Main output level control.
- Record output.
- "MIX" input to connect another mixer or equipment.
- "MUTE" remote control input: allows connection of fire detection systems or any other safety device that have to mute the mixer by activating this control signal (internally selectable as "NO / NC", normally open / normally closed).
- Mono / Stereo selector.

5. INSTALLATION

The SAM412T mixer has been specially designed to be installed in a standard 19" rack, taking up 1U. It has been designed to be operated by non-technical users. This is the reason why its tone controls are adjustable only with a screwdriver. On the opposite, input and output level controls use classic and easily accessible rotary knobs.

Due to its low power consumption and heat sink, the SAM412T doesn't need any fan cooling. However, avoid installing it in dusty environments and/or in a location with extreme temperature and moisture.

The mixer should be kept apart from noise and interference sources (dimmers, motors, etc...) as well as from power cables.

The SAM412T is powered by alternating current through its external power supply: 100-240 VAC and 50-60 Hz. This external PSU has interchangeable connectors: American, European, British and Chinese.

In order to protect the mixer from eventual overloads, the SAM412T is protected by a timered power fuse (24) of 0.5A. If it gets blown up, you must replace it with an identical one. If it gets blown up, you must replace it with an identical one. **NEVER REPLACE THE FUSE WITH ANOTHER ONE WITH A HIGHER VALUE.**



CAUTION: Fuse substitutions have to be performed by a qualified technician.

6. INPUTS

Each SAM412T channel has two input types (MIC/mono, LINE/stereo), selectable using a switch on the back panel:

Microphone signal (11): the four mixing channels are provided with screw terminal strips and accept a nominal input level from -50dBV (3.16mV) to -20dBV (0.1mV), to be adjusted on the back panel (12).

There is also another **jack input for microphone** on the front panel (1), connected in parallel with the one for the same channel on the back panel.

Here is the wiring diagram for microphones:

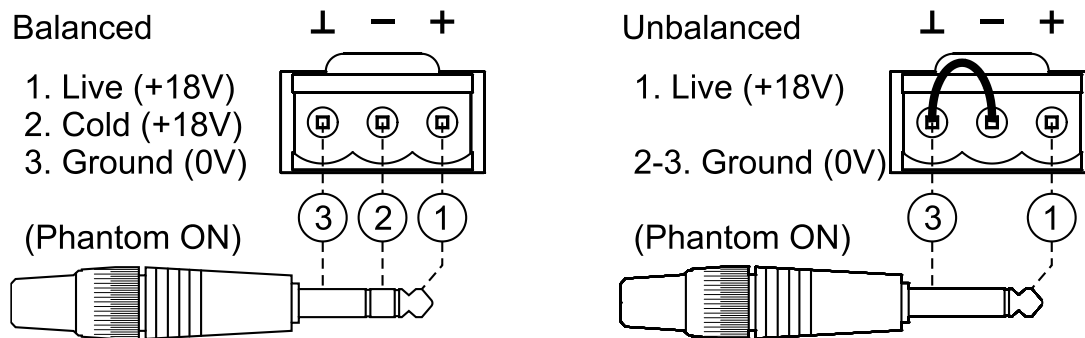

Note: Microphones must be low impedance (200 to 600Ω) and monophonic.

The SAM412T have a **Phantom power supply** for condenser microphones, individually switchable by internal jumpers (for each microphone). Cf diagram.

Note: The *Phantom* power supply is activated by default (factory setting).

The **Talkover function** is activated when a signal presence is detected on Input 1. Then it attenuates the other unit inputs. It can be activated/deactivated by the "TK" switch (2), located on the front panel.

Given the important level differences between usual LINE and CD sources, the SAM412T provides specialized inputs for each source. The sensitivity of the "LINE"(14) input is 0dBV (1V), while the "L LINE" (15) sensitivity is -5dBV (562mV). CD Players, DAT, MP3, and DVD Audio should be connected to the "LINE" input. Tape players, tuners and some production devices (samplers, sequencers) should be connected to the "L LINE" input.

WARNING: Turntables **CAN NOT** be directly connected to this unit, because SAM412T has no RIAA preamp equipped input.

In addition, **MIX IN** (16) input directly access to the main mixing bus. It is especially useful to connect a second SAM412T or another mixer in order to increase the number of mixing channels and inputs.

7. OUTPUTS

The SAM412T has two main outputs, with their type of connector as only difference: electronically balanced screw terminal strips (18, 19) and unbalanced RCA connectors (21).

Connection is made according to the following diagram:

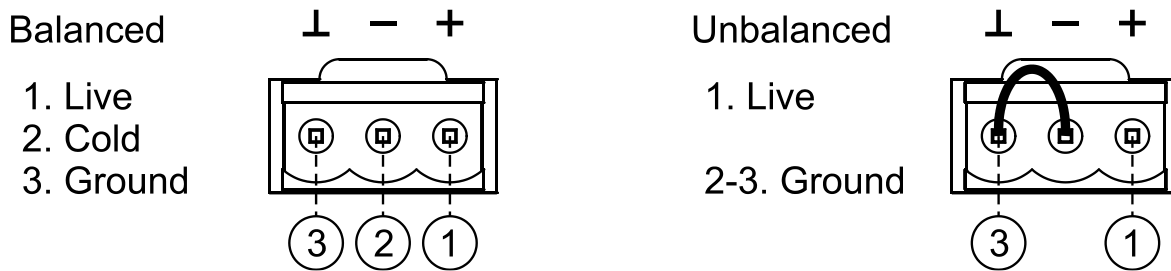

In order to use a unbalanced output, you need to short pin 2 and pin 3, as indicated in the previous diagram. Otherwise, the output signal won't have the right level and quality.

The mixer's main output level (**OUTPUT VOL** (7)) must be set in order to avoid your system power amp clipping indicators (CLIP) to be permanently lit. Only the most powerful lower frequencies must light them.

Other connections on the back panel:

- **REC output** (17), 0dBV nominal, 10k Ω .
- **L+R switch** (20): convert output signals in a mono signal.
- **MUTE remote control input** (22): external contact closure input. Allows connection of fire detection systems or any other safety device that have to mute the mixer by activating this control signal. The operating mode is internally selectable by jumpers as "NO / NC" (normally open / normally closed).

8. STARTING UP

This is directly done via the POWER mains switch (10). Even is the power-up noise of SAM412T is minimal, we highly recommend to power up all equipment in the following order: sound sources, mixing units, equalizer, processors and finally power amplifiers. The power down sequence is the inverse of the power up one.

9. EQUALIZATION

Tone controls (4, 5, 6) provide ± 15 dB gain/attenuation for each of the three bands, centered on 100Hz, 2kHz and 10kHz. Given this unit's application philosophy, tone controls are designed to be set with a screwdriver, thereby preventing accidental manipulation during normal usage.

10. VU-METER

The SAM412T has a VU-meter (9) to show the main mixing signal.

11. GROUND LOOPS, BACKGROUND NOISE

You should always make sure that the signal sources coming to the unit, as well as all devices connected to its outputs, do not have their grounds interconnected, that is; ground must never come from two different devices. Should this ever happen, noises could occur and seriously interfere the sound quality.

Cable shields, when connected to the chassis, must never be linked together. This will avoid ground loops.

The SAM412T mixer was designed to produce the lowest background noise. Independently from the electronic design, the resulting background noise directly relies on the correct use and installation of the mixing unit.

I. e.: setting a channel VOL to "2" and the output to "10" is not the same as the other way round. In the first case, the signal coming to the mixing amplifier - which has got its own noise - is low, and so is the signal-to-noise ratio (low signal). When the output amplifier boosts the whole signal we will get a very high background noise. In the second case - with the channel fader at maximum - the mixing level is high, and so is the signal-to-noise ratio. When the signal reaches the VOL OUTPUT and is boosted, it will keep a much better signal-to-noise ratio than in the preceding case.

12. CLEANING

The front panel should not be cleaned with dissolvent or abrasive substances because silk-printing could be damaged. To clean it, use a soft cloth slightly wet with water and neutral liquid soap; dry it with a clean cloth. Be careful that water never gets into the unit through the holes of the front panel.

13. DIAGRAMS

13.1. Control Panels Function

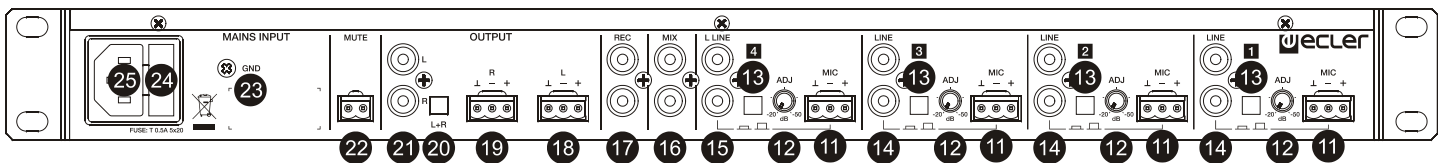
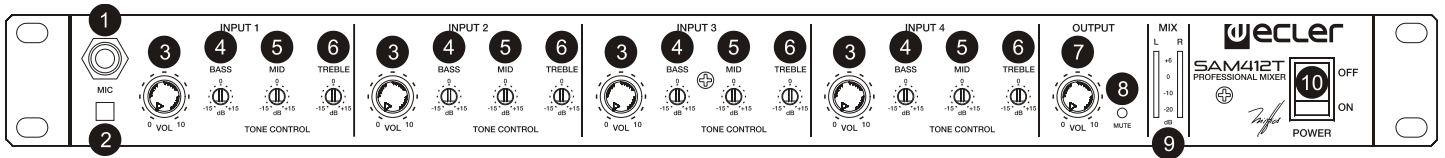

- | | | | |
|----|--|----|--|
| 1 | input, MIC | 11 | Micro input, MIC |
| 2 | Talkover switch, TK | 12 | Microphone input sensitivity adjust, ADJ |
| 3 | Channel volume control, VOL | 13 | Micro line selector |
| 4 | Bass control, BASS | 14 | Line input, LINE |
| 5 | Midrange control, MID | 15 | Line input, L LINE |
| 6 | Treble control, TREBLE | 16 | Mix input, MIX |
| 7 | Output main volume control, OUTPUT VOL | 17 | Recording output, REC |
| 8 | LED indicator, MUTE | 18 | Main output, left channel, OUTPUT L |
| 9 | Led Vu-meter, MIX | 19 | Main output, right channel, OUTPUT R |
| 10 | Mains switch, POWER | 20 | Mono-stereo switch, L+R |
| | | 21 | Main output, OUTPUT |
| | | 22 | Screwable terminal for remote mute, MUTE |
| | | 23 | Ground terminal, GND |
| | | 24 | Fuse holder |
| | | 25 | Mains socket |

13.2. Side Position

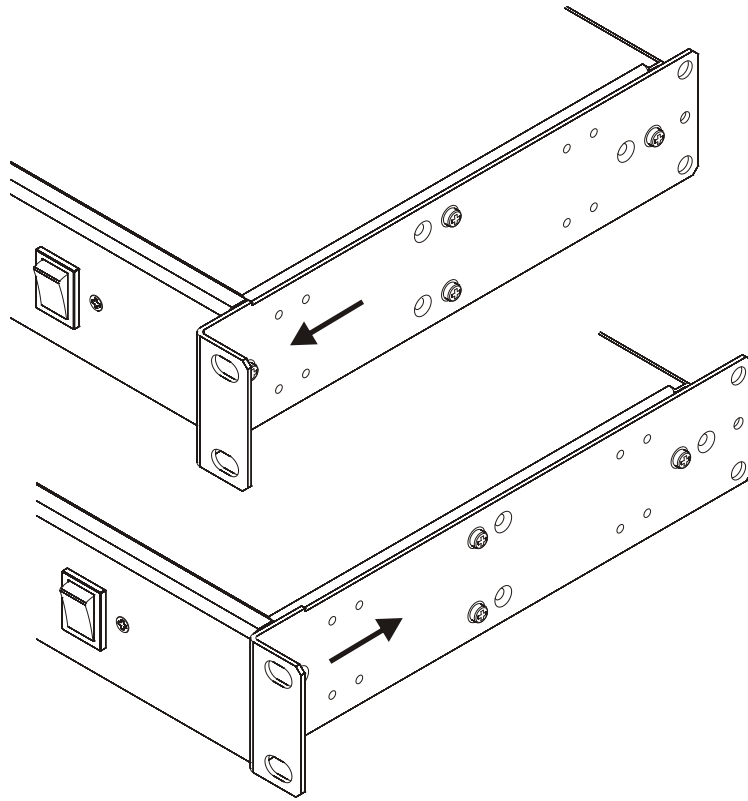

13.3. Configuration Diagram

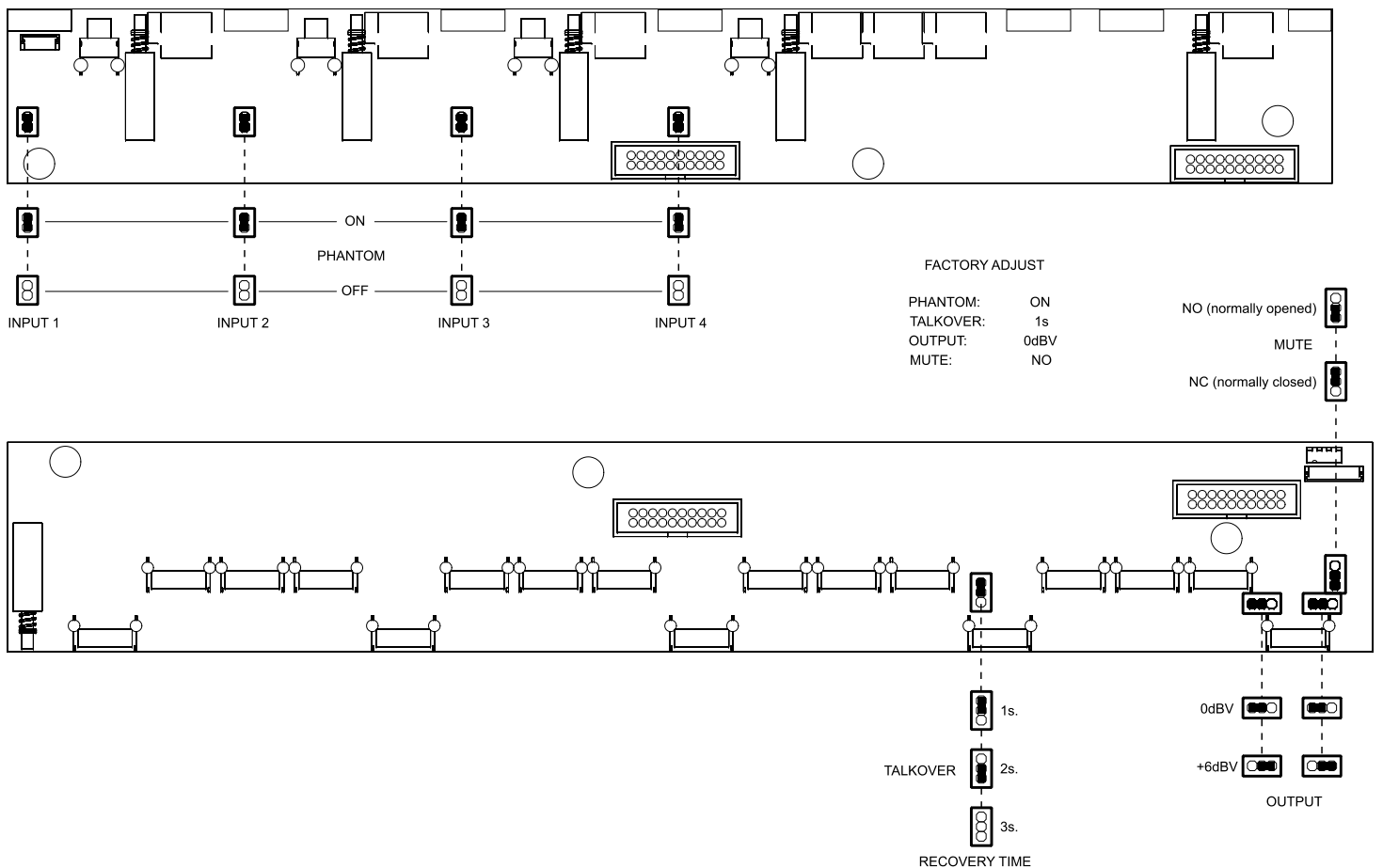

13.4 Block Diagram

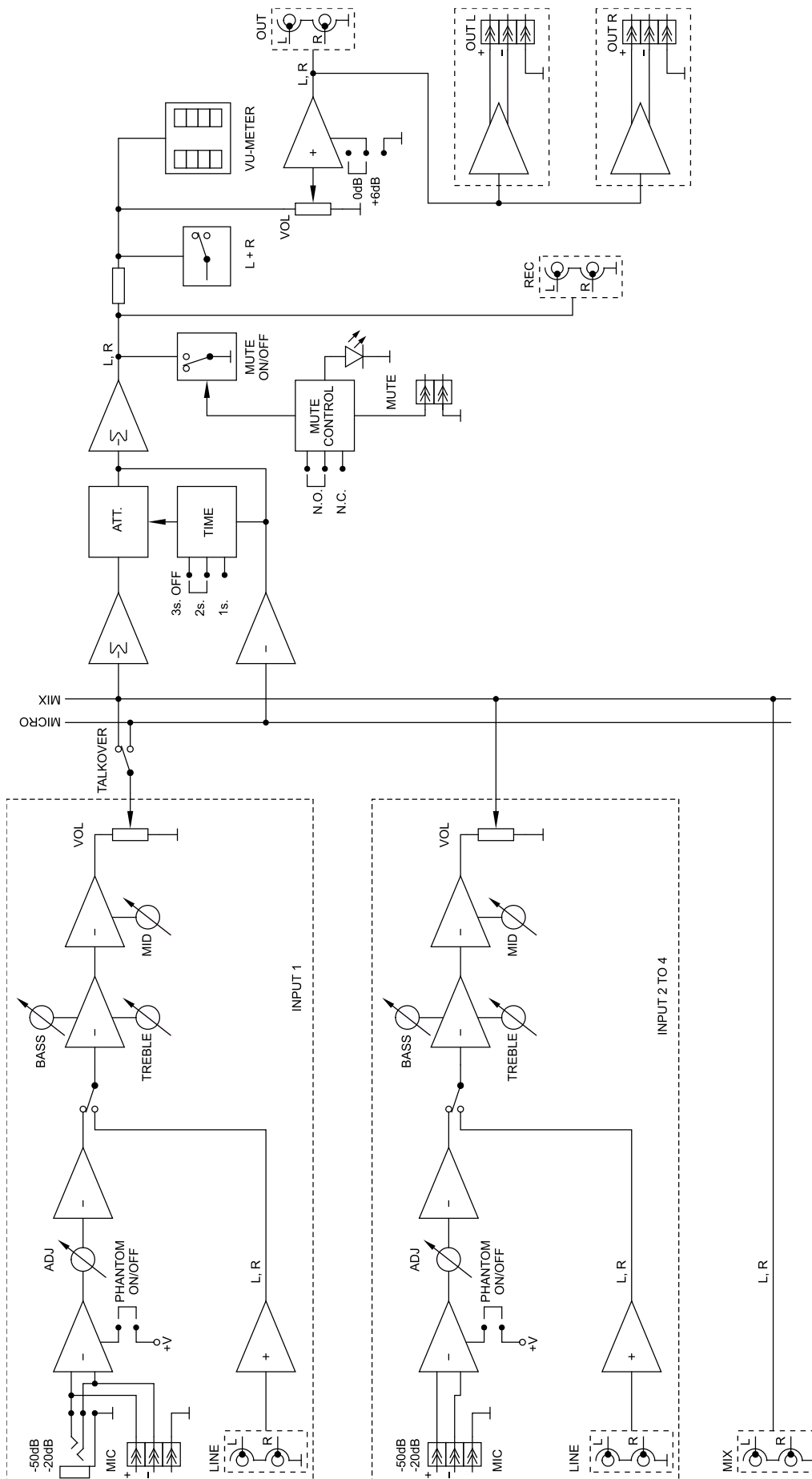

14. TECHNICAL SPECIFICATIONS

SAM412T

| Inputs Sensitivity nom(*)/Impedance | |
|-------------------------------------|-----------------------------------|
| LINE(1, 2, 3) | 0dBV/50Ω |
| L LINE(4) | -5dBV / 50kΩ |
| MIC BAL | -50(-20)dBV/>1kΩ |
| MIX | 0dBV>6Ω |
| Outputs Level/Minimum load | |
| OUT 1 BAL | 0(+6)dBV*/600Ω1(2)V |
| OUT 1 UNBAL | 0(+6)dBV*/2.2kΩ 1(2)V |
| REC | 0dBV/10kΩ |
| Frequency response | |
| LINE | 10Hz-50kHz -1dB |
| MIC BAL | 10Hz-30kHz -1dB |
| Harmonic distortion | |
| LINE | <0.01% |
| MIC BAL | <0.04% |
| CMRR | |
| MIC | >65dB@1kHz |
| Signal/Noise ratio | |
| LINE | >100dB |
| MIC BAL | >85dB |
| Tone control | |
| BASS | 100Hz ±15dB |
| MID | 2kHz ±15dB |
| TREBLE | 10kHz ±15dB |
| Talkover | |
| TIME | 1 / 2 / 3 seg* |
| EFFECT | -30 dB |
| Phantom voltage | +18VDC |
| DC supply | ±17,5 VDC |
| Mains | 100-240VAC + External PSU 17,5VDC |
| Power Consumption | 23VA |
| Dimensions | |
| Panel | 482.6x44mm |
| Depth | 195mm |
| Weight | 2.4kg |

(*) Internally selectable



All product characteristics are subject to variation due to production tolerances. **NEEC AUDIO BARCELONA S.L.** reserves the right to make changes or improvements in the design or manufacturing that may affect these product specifications.

For technical queries contact your supplier, distributor or complete the contact form on our website, in [Support / Technical requests](#).

Motors, 166-168 08038 Barcelona - Spain - (+34) 932238403 | information@ecler.com | www.ecler.com