

# NIC-3

## LOUDSPEAKERS

*In-ceiling / In-wall Loudspeaker*



### PRODUCT OVERVIEW

**NIC-3** is a 1-way in-ceiling / in-wall loudspeaker designed for 70/100 V line and low-impedance sound systems, delivering 20 W RMS and featuring a 3" full-range woofer for compact, discreet installations requiring high intelligibility and balanced sound.

As part of the NIC Series, NIC-3 benefits from an acoustic back-can with resonator design, helping to enhance low-frequency response while minimising unwanted resonances and coloration when installed in lightweight or suspended ceilings.

The loudspeaker is IP66 rated, making it suitable for humid or dusty environments, and features a frameless aluminium front grill with bayonet fixing for fast installation and a clean, minimalist aesthetic. The removable Ecler logo allows discreet visual integration.

### APPLICATIONS

- Retail
- Hospitality
- Education
- Corporate
- Leisure
- Sport & Wellness

### ACCESSORIES & COMPATIBLE PRODUCTS

- NICRG3BK

### TECHNICAL SPECIFICATIONS

NIC-3	
System	
Effective frequency range <sup>1</sup>	112Hz-20kHz (-10dB)
Coverage angle <sup>2</sup>	172° conical
Continuous Power handling <sup>3</sup>	20W
Program Power Handling <sup>4</sup>	40W
Peak Power Handling <sup>5</sup>	80W
On-axis Sensitivity <sup>6</sup>	85dB
Maximum SPL <sup>7</sup>	95dB continuous / 101dB peak
Power options	20W - 8Ω / 10W-100V-70V
Recommended amplifier power	40W RMS
Transducers	
Configuration	1-ways full range
Low frequency driver	3" Woofer
Nominal impedance	8Ω
Physical	
Connection type	Clip-Type input terminals
Installation options	In-ceiling / In-wall
Enclosure material	ABS plastic
Environmental	IP66
Grill material	Aluminium
Grill fixing system	Bayonet
Mounting system	2 rotating tabs
Operating temperature	Min: -30°C ; -22°F Max: 65°C ; 149°F
Operating humidity	<85% HR
Storage temperature	Min: -30°C ; -22°F Max: 65°C ; 149°F
Storage humidity	<85% HR
External diameter	113.5 mm / 4.47 in.
Internal diameter	97 mm / 3.82 in.
Recommended cut out diameter	100 mm / 3.94 in.
Required depth	>120 mm / >4.72 in.
Ceiling thickness	Min: 10 mm / 0.39 in. Max: 60 mm / 2.37 in.
Included accessories	4 pin connector
Optional accessories	NICRG3BK (Grille Black accessory -RAL 9005-)
Finished colour	White (RAL 9003)
Dimensions (WxHxD)	113.5 x 113.5 x 95 mm / 4.47 x 4.47 x 3.74 in.
Weight	0.54 Kg / 1.19 lb
Pieces per box	1
Shipping dimensions (WxHxD)	155 x 145 x 145 mm. / 6.10 x 5.71 x 5.71 in.
Shipping weight	0.86 kg / 1.90 lb

<sup>(1)</sup> Measured frequency range within -10dB of the 1kHz octave band level, according to IEC 60268-5.

<sup>(2)</sup> Beamwidth defined at -6 dB relative to the on-axis sound pressure level, using the maximum value within the 1kHz to 4kHz range.

<sup>(3)</sup> RMS input power applied via IEC shaped band-limited pink noise for 2 hours, per AES2 power handling standard.

<sup>(4)</sup> Conventionally 3 dB higher than the RMS measure, intended to represent real music signals.

<sup>(5)</sup> Corresponds to the signal crests during for the test described in (3).

<sup>(6)</sup> Sound pressure level at 1m with 1W input at nominal impedance under half-space radiation conditions.

<sup>(7)</sup> Calculated.

## POLAR DIAGRAMS

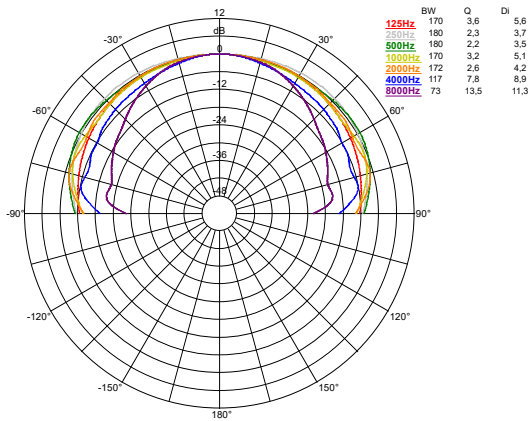

## FREQUENCY RESPONSE ON-AXIS

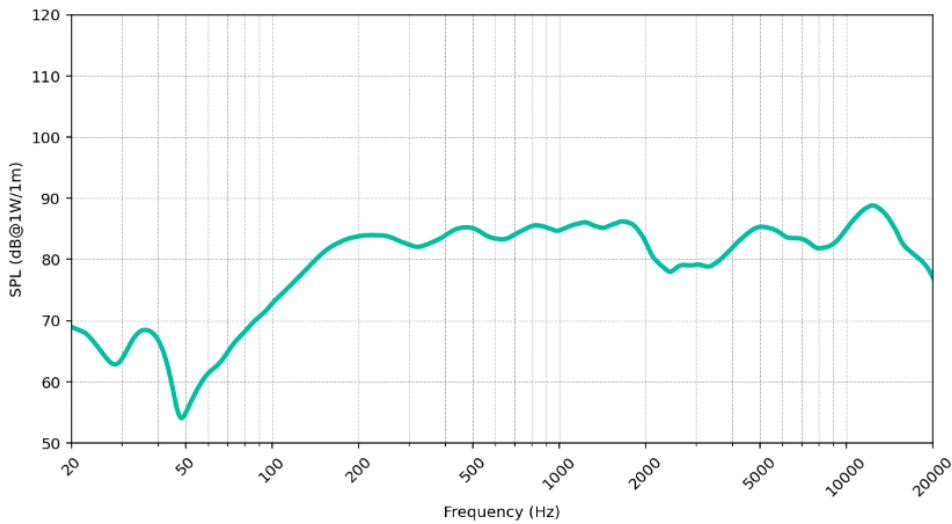

## MECHANICAL DIAGRAM

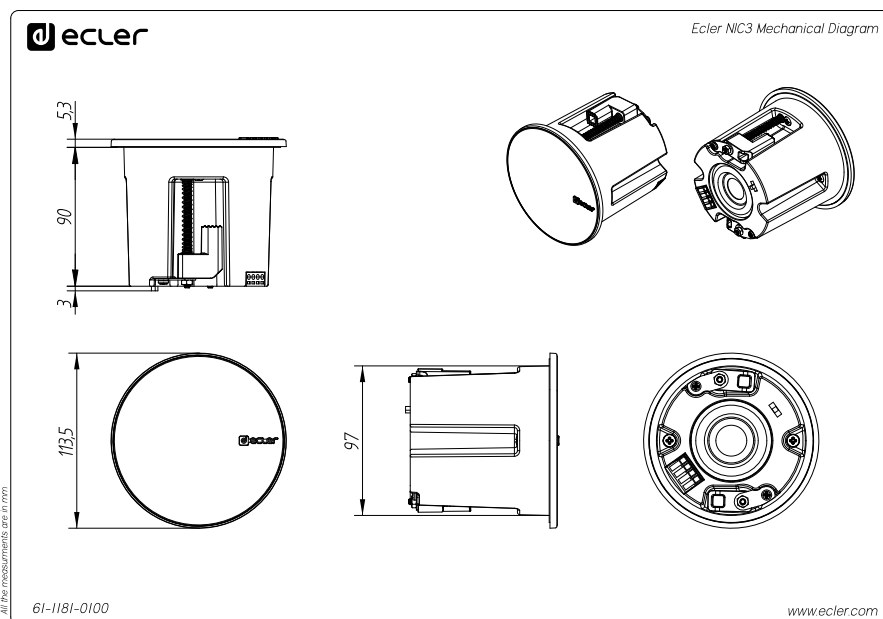

All product characteristics are subject to variation due to production tolerances.

NEEC AUDIO BARCELONA S.L. reserves the right to make changes or improvements in the design or manufacturing that may affect these product specifications.

For technical queries contact your supplier, distributor or complete the contact form on our website, in [Support / Technical requests](#).

Motors, 166-168 - 08038 Barcelona – Spain | Tel. (+34) 932238403 | [information@ecler.com](mailto:information@ecler.com) | [www.ecler.com](http://www.ecler.com)